

CORN COB POST TOP

Specifications

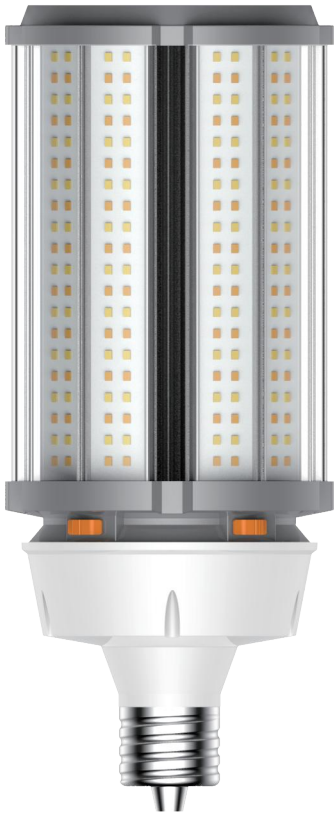

Item	- 36688B
Model	- LED120CC/3CCT/80W/100W/120W EX39
Bulb Shape	- Corn Cob Post Top
Beam Spread	- 360°
Input Voltage	- 120-277VAC 50/60Hz
Watts	- 80W/100W/120W
Base Type	- EX39
Color Temp	- Selectable (3K/4K/5K)
CRI	- 80
Lumen	- 11200/14000/16800
Dimmable	- Yes with optional sensor and remote
UL Rating	- Suitable for Dry/Damp Locations
Enclosed Rated	- Yes
Minimum Lamp Enclosure Dimensions	- 11.81" x 11.81" x 14.24"
Life	- 50,000 Hours
Ambient Operating Temp	- -40°F to 113°F (-40°C to 45°C)
Diameter	- 5.12" (130.0mm)
Length	- 12.47" (316.8mm)
Surge Protection	- 4KV
	- Type B, ballast must be bypassed

Caution

- Use only on 120-277 VAC 50/60Hz circuits. This device is not intended for use with emergency exit fixtures or emergency lights.
- This lamp is not compatible with dimmers. During installation, ensure that the power is switched off prior to connecting or disconnecting the lamp from the fixture.
- No user serviceable parts inside. To avoid electrical shock, do not disassemble the product.
- RISK OF BURN--Disconnect power and allow fixture to cool before servicing.
- To prevent injury or property damage from falling lamp, only use in fixtures that can structurally support this lamp.
- The condition of the lamp holder can affect the life hours of a bulb. Inspect the lamp holder regularly for deterioration. If deterioration has occurred, replace the lamp holder immediately before continuing operation.

Precaución

- Use solo en circuitos de 120-277 VAC 50/60 Hz. Este dispositivo no está diseñado para su uso con dispositivos de salida de emergencia o luces de emergencia.
- Esta lámpara no es compatible con atenuadores. Durante la instalación, asegúrese de que la alimentación esté desconectada antes de conectar o desconectar la lámpara del dispositivo.
- No hay piezas reparables por el usuario dentro. Para evitar descargas eléctricas, no desarme el producto.
- RIESGO DE QUEMADURAS - Desconecte la energía y permita que el accesorio se enfríe antes de realizar el servicio.
- Para evitar daños o daños a la propiedad por la caída de la lámpara, solo use accesorios que puedan soportar estructuralmente esta lámpara.
- La condición del portalámparas puede afectar las horas de vida de una bombilla. Inspeccione el portalámparas regularmente para ver si está deteriorado. Si se produce un deterioro, reemplace el portalámparas inmediatamente antes de continuar con la operación.

Warning

Risk of electric shock

- Disconnect electrical power to fixture and follow proper lockout/tag out procedures before installation or maintenance. Contact a qualified electrician for installation.
- This device requires 120-277VAC input voltage.
- This device requires all ballasts, capacitors, and starters to be bypassed/removed.
- Suitable for use in damp locations. DO NOT use where directly exposed to liquid, vapor, rain.
- Added weight of the device may cause instability of a free-standing portable luminaire.
- This device is not intended for use with emergency exits.
- This device is intended for use with motion sensor or infrared sensor.
- This device is suitable for enclosed fixtures. Min. lamp compartment dimensions 11.81" x 11.81" x 14.24".
- If included the safety cable must be installed and attached securely to the fixture.

CCT & Power Selectable

- CCT Selectable: Select your desired CCT by sliding the switch as below picture shows.
 - Power Selectable: Select your desired wattage by sliding the switch as below picture shows.
- NOTE: PLEASE SELECT THE DESIRED CCT OR WATTAGE BEFORE LIGHTING UP THE LAMPS.

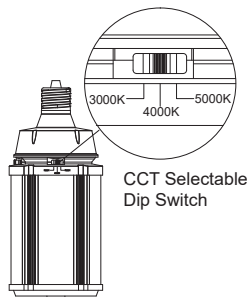

CCT Selectable Dip Switch

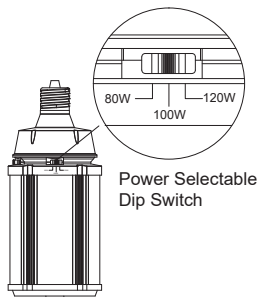

Power Selectable Dip Switch

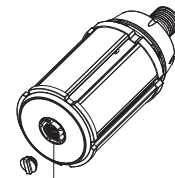

Socket for motion sensor or infrared sensor

Installation

Lamp Installation

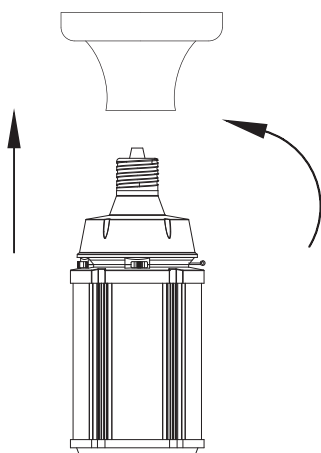

Step:1

Shown as Figure 1
Remove old ballast or disconnect from existing lamp holder. Remove and dispose of ballast in correct manner.
(Input voltage 120-277VAC)

Step:2

Shown as Figure 2
Reconnect directly to the existing lamp holder.
(Input voltage 120-277VAC)

Step:3

Shown as Figure 3
Install new LED replacement lamp. Please make sure the old fitting is correctly grounded.
(Input voltage 120-277VAC)

